

Tool Board

Assembly Instructions

Thank You!

for purchasing your Mo-Clamp tool board with tools. Each tool board requires a certain set of hardware/hooks designated for each individual tool. Note the diagram on the right showing how to install the hooks on the board. Below you will find a diagram that fits your board indicating the need for a short "L" hook (2"), a long "L" hook (2 3/4"), or a "J" hook (designed for tools that hang sideways).

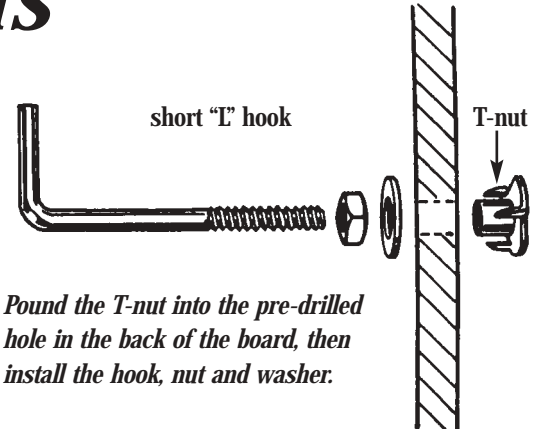

#5010 No. 1

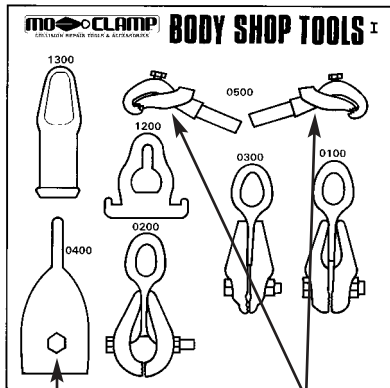

"J" (2) long "L"
[All the rest are short "L"]

#5020 No. 2

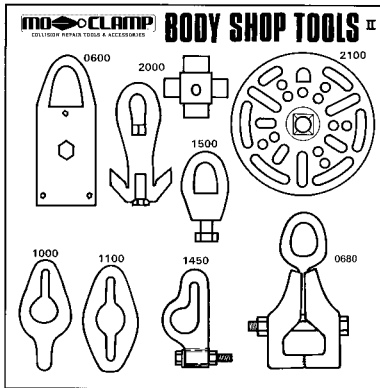

[All are short "L"]

#5050 No. 5

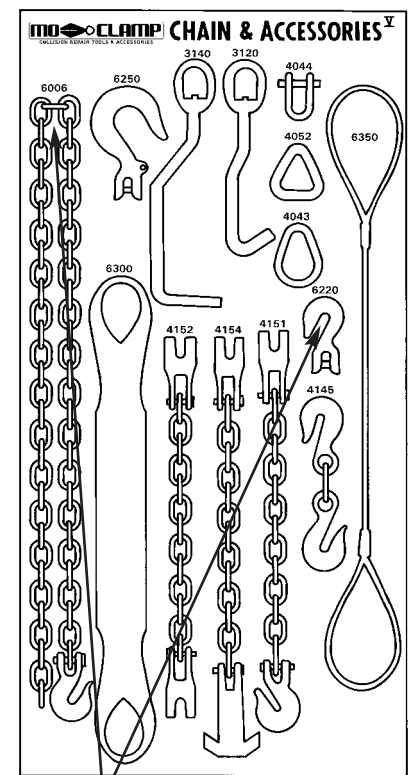

long "L"
[All the rest are short "L"]

#5025 No. 3



"J" long "L"
[All the rest are short "L"]

#5040 No. 4

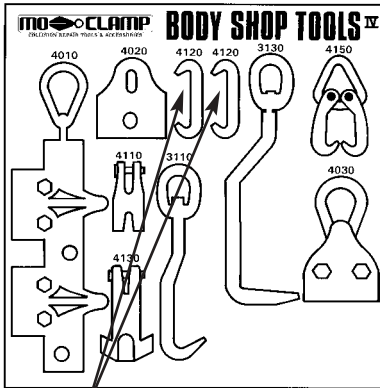

long "L"
[All the rest are short "L"]

6920 SW 111th Avenue, Beaverton, OR 97008 USA
800-678-5548 • (503) 644-9167 • Fax (503) 644-2733
www.moclamp.com email: sales@moclamp.com

© Pull-It Corporation 5.01



#5060 No. 6

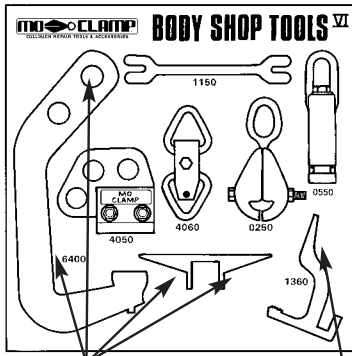

long "L"
[All the rest are short "L"]

#5066 No. 7

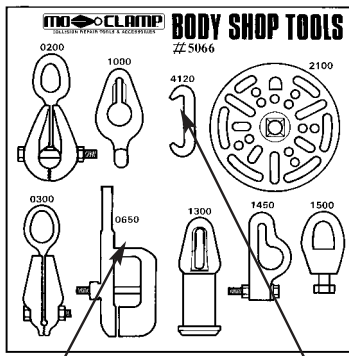

long "L"
[All the rest are short "L"]

#5095 No. 8

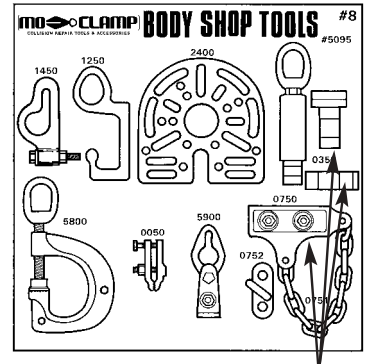

(6) long "L"
[All the rest are short "L"]

#5090 No. 9



[All the rest are short "L"]

#5056 Starter "A"

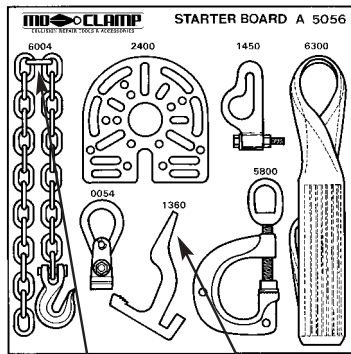

long "L"
[All the rest are short "L"]

#5058 Starter "B"

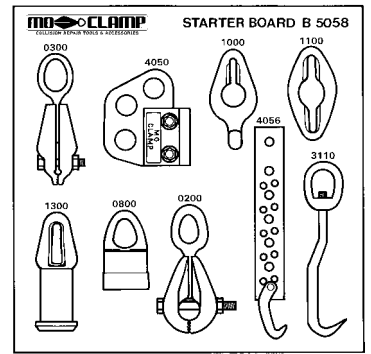

[All are short "L"]

#7400

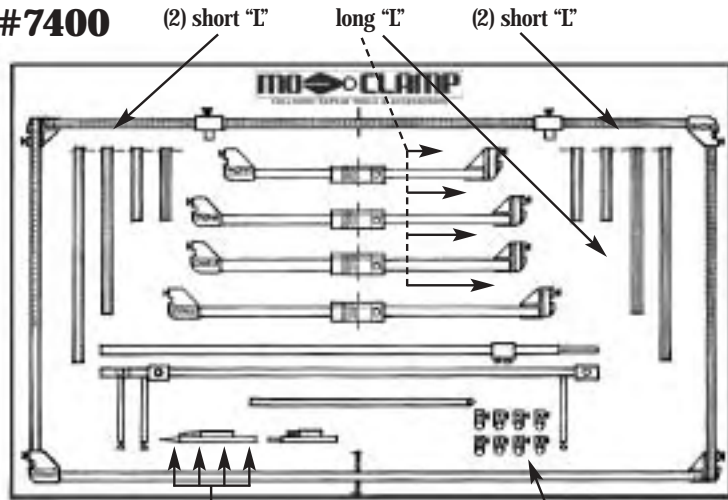

(4) long "L" [All the rest are short "L"] (2) long "L"

#5078 No. 10

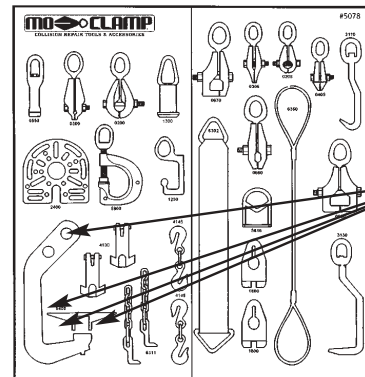

[4] long "L"
[All the rest are short "L"]

#5100 No. 12

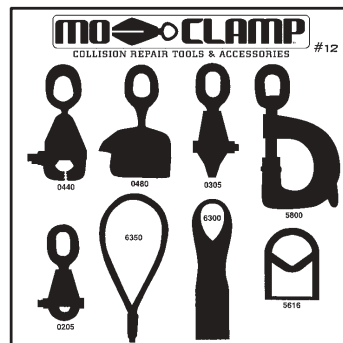

[All are short "L"]



6920 SW 111th Avenue, Beaverton, OR 97008 USA
800-678-5548 • (503) 644-9167 • Fax (503) 644-2733
www.moclamp.com email: sales@moclamp.com

© Pull-It Corporation 5.01